



ATLUSTM
We Make People Moving

WE MAKE 
PEOPLE MOVING



- Manufacturing
- Installation
- Maintenance
- Modernisation



COMPANY PROFILE

ATLUS LIFT was Established in Year - 2018. It is Manufacturing Sales and Maintenance company that provides exceptional customer service and high quality work to commercial and residential properties. We believe in readiness and are always on our toes to stand strong on our commitment of our customer needs. Our aim is to provide safety with comfort and cost effectiveness. We have a strong team of qualified, experienced and efficient staff to give us the quality product which holds us high in the elevator industry. We work with a motto to satiate our clients on all fronts through our quality elevator products. We offer a complete range of lift services and maintenance, from a single lift to a full portfolio of lifts on multiple sites across all over Nepal. We are manufacturers of all types of elevators such as Passenger Lifts, Goods Lifts, Hospital Lifts, Hydraulic Lifts, Auto door Lifts, Capsule Lifts and MRL lifts.

Our Mission

To provide total customer satisfaction and achieve leadership in chosen markets, products and services across the globe, through excellence in technology, based on world-class research and development.

Our Vision

Our Vision is to be the leading elevator company in world wide elevator industry and to become a global enterprise by providing high quality, affordable and innovative solutions to elevator industry. We seek to put to application the most modern techniques in an indigenous way to suit varied needs.

We at Atlus offer following type of elevator



Traction Machine
Room Elevator



Goods
Elevator



MRL Gearless
Elevator



Parking
Elevator



Home
Elevator



Capsule
Elevator



Hospital
Elevator



Hydraulic
Elevator



EFFICIENT

Smooth and reliable logistics line comes from the advanced frequency conversion asynchronous traction machine.

Traction Technology

Stable and Reliable Performance

Traction lift dedicated host optimizes the traditional design, greatly improve the stability of the motor and reduce the noise pollution.

Simple Structure, Easy Maintenance

Use a mature technology of asynchronous motor, stable and reliable mechanical components, simple structure, loss reduction and easy maintenance, using costs go down correspondingly.

Powerful Carrying, Create Value

Traction elevator dedicated host has different levels of load carrying capacity; it's convenient to use for users, maximum carry is upto 20 person. For users' efficient transport, bring attractive profit.



AUTO DOOR

Passenger Elevator



The stylish way to Brand your Elevator

Capacity
06 To 20 Passenger

ATLUS LIFT has been engineered with full automatic doors. Fabricated with most advanced lift controls, appreciated for their high speed, smooth travel and perfect leveling different types of doors Centre Opening, Telescopic Opening.

- In high density requirements, we can provide grouping of multiple elevators to reduce the waiting time of the passengers.
- Our proficiency allows us to design and develop Passenger Elevators of various sizes and capabilities.
- It gives benefits of jerk less travelling, economically low power consumption and excellent design.

LOAD		LIFT WELL		CAR INSIDE		ENTRANCE	MACHINE ROOM			SPEED UPTO 1M/S	
Person	Weight	Width	Depth	Width	Depth		Width	Depth	Height	Pit	O.H.
IN KG		A	B	C	D	E	F	G	H		
4	272	1900	1300	1100	700	700	2900	3300	2500	1500	4800
6	408	1900	1700	1100	1000	700	2900	3700	2500	1500	4800
8	544	1900	1900	1300	1100	800	2900	3900	2500	1500	4800
10	680	1900	2100	1300	1350	800	2900	4100	2500	1500	4800
13	884	2500	1900	2000	1100	900	3500	3900	2500	1500	4800
16	1088	2500	2100	2000	1300	900	3500	4100	2500	1500	4800
20	1360	2500	2400	2000	1500	2000	3500	4400	2500	1500	4800

* All Dimension are in mm. * This is General Date. It may be changed without notice. * All hoist way walls should be minimum 230 mm brick or 150 mm R.C.C.

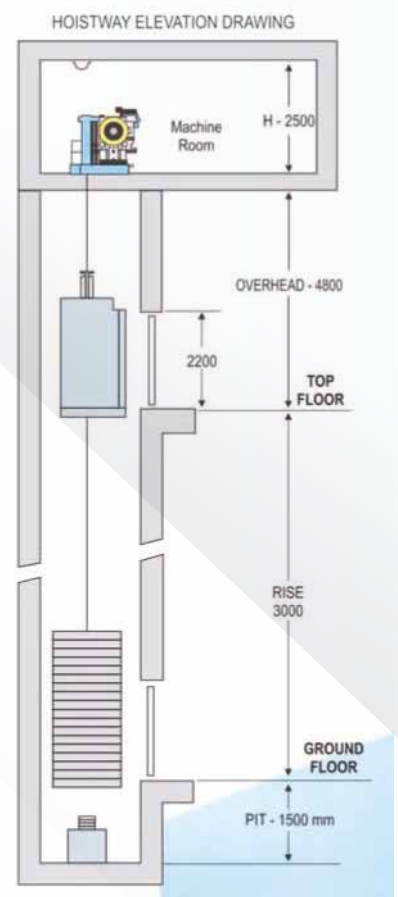
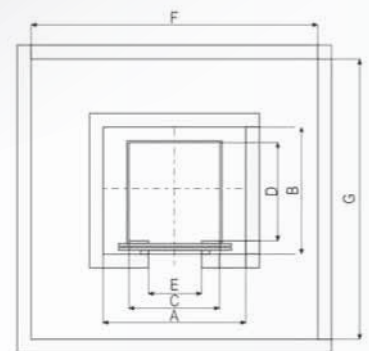

Top grade door Machine system

Fully computerized VVVF Closed-loop control mode fulfills the smooth operation. It needs no position switch. Internal self-tuning function records various floor door widths by memory. It ensures the accurate and proper door-opening.



HOSPITAL ELEVATOR

Strature Elevator



**Relax Your Mind,
Your Body, Your Sprit**

Capacity
15 To 26 Passenger

ATLUS LIFT Bed elevators a purpose designed solutions for hospitals and renowned for fine quality and robust performance.

- A wide range of Car dimensions is available for the varying requirements of a modern hospital.
- The entire system is Safe and reliable operating Steadily.
15 To 26 Passenger
- Features : Accurate Open and Shut Control, Stable and Smooth.

Automatic Center Opening Door

Automatic Telescopic Door

PERSON	CAPACITY	SHAFT-W	SHAFT-D	CAR-W	CAR-D	SHAFT-W	SHAFT-D	CAR-W	CAR-D	ENTRANCE
	KG.	A	B	C	D	A	B	C	D	E
15	1020	1800	3000	1000	2400	1700	3000	1000	2400	800
20	1360	2200	3000	1300	2400	1950	3000	1300	2400	1200
26	1768	2400	3000	1600	2400	2100	3000	1600	2400	1200

* All Dimension are in mm. * This is General Date, it may be changed without notice. * All hoist way walls should be minimum 230 mm brick or 150 mm R.C.C.

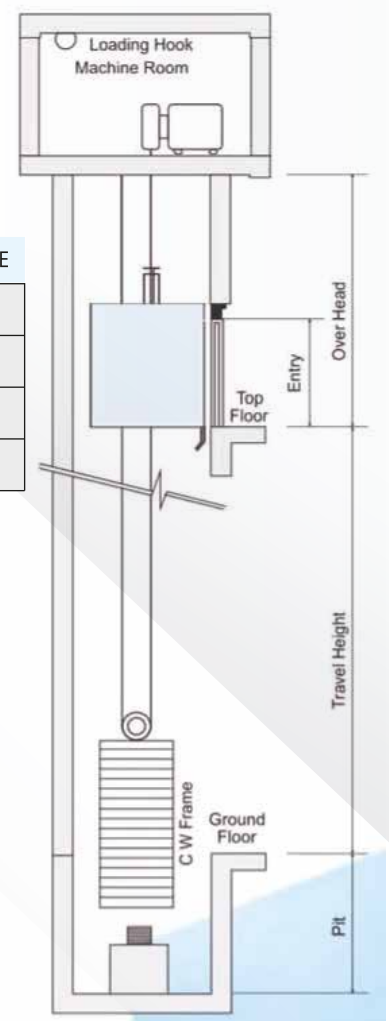
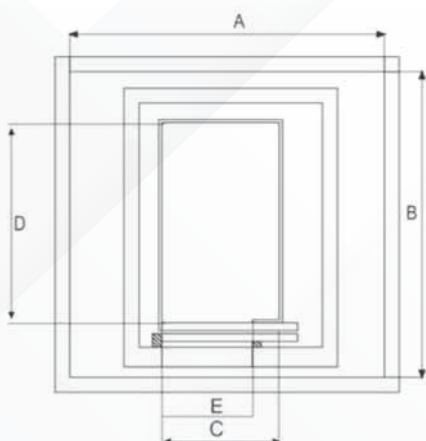

MRL ELEVATOR

Machine Roomless Elevator



Step up Revolution

Capacity

05 To 26 Passenger



Low Noise



High Efficiency & Energy Saving



Green Environmental Protection

The Machine roomless elevators incorporate environment concern by using energy saving machines and low noise controller. It also saves construction space which totally reflects the idea of environment friendly culture.

Compared with gear load elevators (having same load capacity), these elevators save about 25% energy and 10% construction area.

Roomless passenger elevators have overcome conventional prerequisites of machine rooms by providing limitless possibilities in creation of elevators which confront with optimal space utilization.

It saves **25%** of total elevator equipment area.

It reduces **40%** of space occupation.

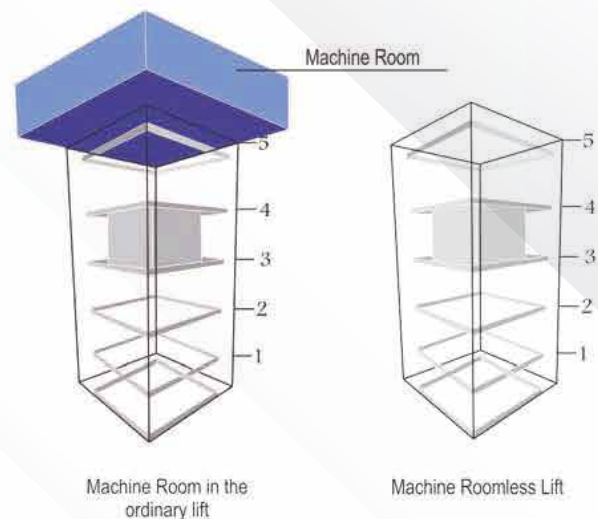

MRL ELEVATOR

Machine Roomless Elevator

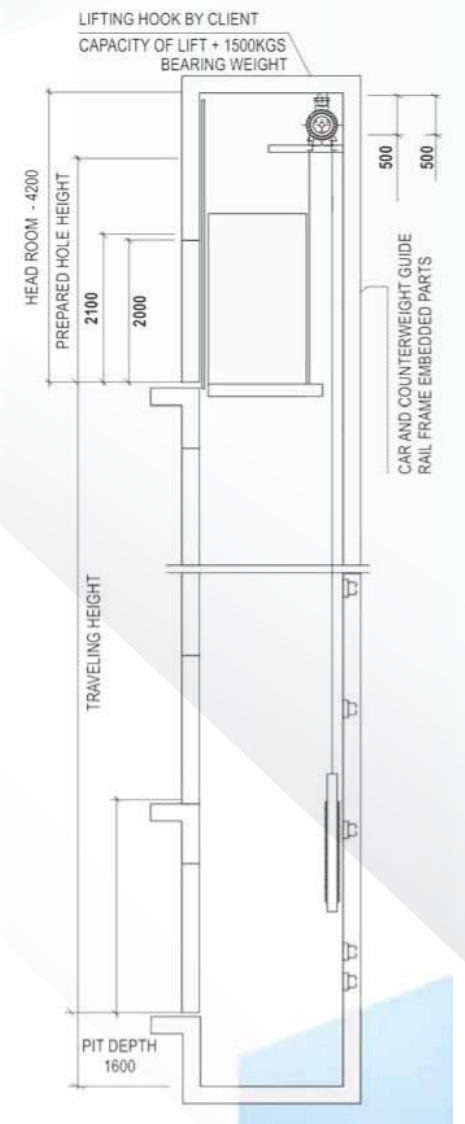
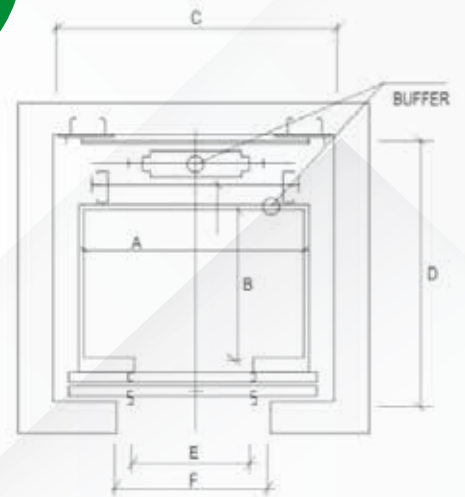

Construction Parameters

CAPACITY		Car Inside		Lift Well		Clear Entrance	Clear Opening At Landing	
Person	KGS	A	B	C	D	E	F Auto Door	F Manual Telescopic
6	408	1200	900	1800	1400	700	780/2100	1450/2350
8	544	1300	1100	1900	1600	800	880/2100	1600/2350
10	680	1300	1300	1900	1800	800	880/2100	1600/2350
13	884	1600	1400	2200	1900	900	980/2100	1700/2350

Above dimension may vary as per different types of and equipments.
All dimensions are in mm.

Advantages:

- ▶ Latest technology in the world.
- ▶ Smooth and swift in operations.
- ▶ Flexible to all building designs.
- ▶ Consumes less electricity.
- ▶ Safe and reliable.



Quality



Environment



Low Noise



Power Saving



Compact Designs



HOME ELEVATOR

Residential Elevator



The stylish way to Brand your Elevator

Capacity
Up To 04 Passenger



Home lift not only increase the value of your home, but can also provide you a stunning showpiece. At the same time, home lifts can allow the disabled and elderly to easily move about a multi-level dwelling.

The term "home lift" commonly refers to a lift enclosed in a shaft, and which can travel vertically as much as 15 m. (SOft.). Home elevators make it easier to carry groceries, laundry or anything else from one floor to another. And today, they're fully customizable - choose from a wide range of materials, such as marble walls or stained glass, to turn your home elevator into an expression of your own unique style!



Low Noise



Saving Energy



Comfortable

DOOR OPERATION	LOAD		LIFT WELL		CAR INSIDE		ENTRANCE	SPEED (MPS)	PIT	OVER HEAD
	Persons	KGS	C	D	A	B	E			
Manual Door	3	204	1100	1200	810	700	700	0.3	550	3100
Manual Door	4	272	1300	1400	800	1200	700	0.3	550	3100
Auto Door	3	204	1250	1250	810	700	700	0.3	550	3100
Auto Door	4	272	1300	1600	850	1150	700	0.3	550	3100

Note: This is our Standard Data, if other special Requirement please Contact us.

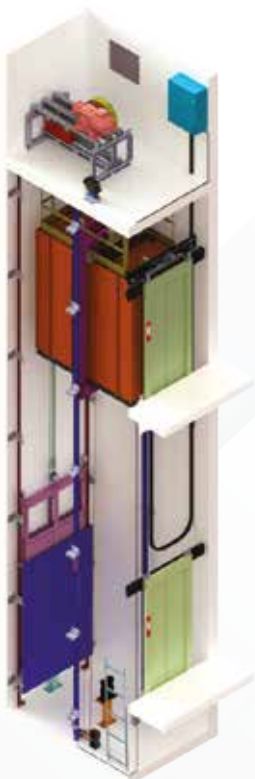

UP-TO 30%
Power Saving
(Single Phase)



Mini Gearless Machine

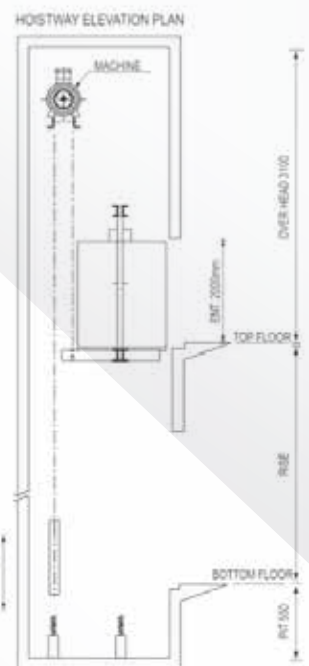
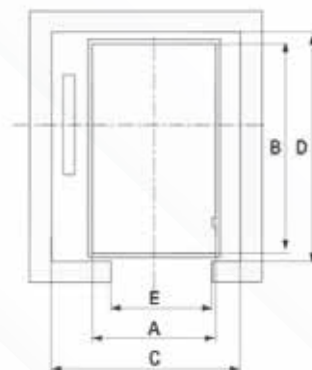

AUTO DOORS



Center Opening Auto Door
(Small Vision)



Center Opening Auto Door
(Big Vision)



Full Glass Auto Door



Center Opening Auto Door



Center Opening Auto Door
(Designer Finish)



Center Opening Auto Door
(Four Panel)

Microprocessor Controller



MRL Control Panel



VVF, ARD
Microprocessor Control Panel

Automatic Rescue Device
(ARD)



Economic Integrated Control Panel



CABINS



Gold Finish With Glass Cabin



M.S. Powder Coated Cabin



S.S. Finish Cabin



S.S. Decorated Cabin



Powder Coated Finish Cabin



S.S. Finish Cabin

LOP & COP



BXK - 191



BCG - 451 COP - LOP



EL 03 COP - LOP



VT-03C



VT-01L



A WIDE CHOICE OF DURABLE INTERIOR MATERIALS

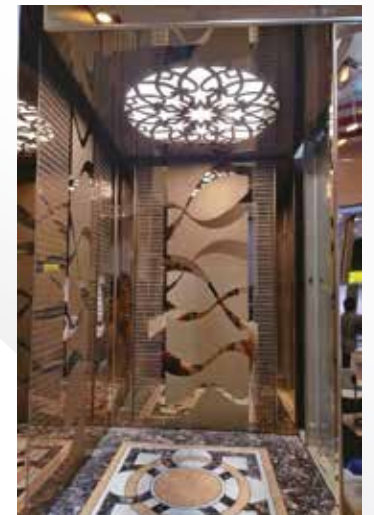

Supply : Lift, Escalator & Lift Modernization



ATLUSTM
We Make People Moving

Manufacturing Unit

📍 27, Alok Industrial Estate, Opp. Vijay sales, Odhav Ring road, Odhav, Ahmedabad - 382415.

☎ +91 9558009323

Nepal Office

Atlas Lift Solution Pvt. Ltd.

📍 Mangalbazar-09, Lalitpur, Nepal

☎ Phone : +977 9851225429, 9808926934, 9851348429

Sub-Branch

Sunidhi Enterprise Pvt. Ltd.

📍 Janakpur-23, Dhanusha, Nepal

☎ Phone : +977 9851225431

